

SW2 Switch, Quad bidirectional switch



The SW2 is a four individual bidirectional switch module in Eurorack format with manual or CV control over the switches.

Bidirectional means that signals can flow in both directions through the switches. You can send signals in to 1 and out on 1G or 1R. Or you can send signals in on 1G and 1R and 1 will be the output.

The switches can be latched in pairs. The layout is for ergonomics when switching stereo buses.

Control of the switches with CV can be done up to well above 100 kHz.

This opens for interesting wave shaping as you can switch out a piece of a cycle of an audio rate signal and replace it with something else, wave splicing. Or change/swap places of your modules in your signal chain at up to high or above audio rate.

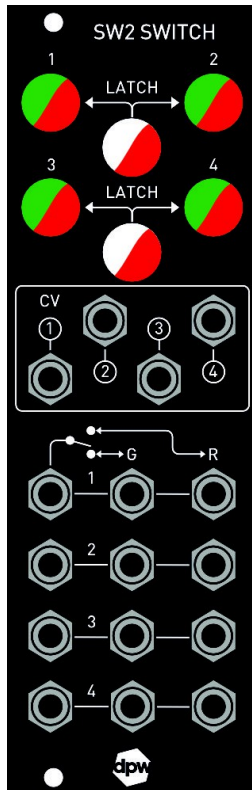

Controls

The switch field is organized as rows of jacks, 1 to 4. The yellow lines on the front panel shows which jacks that are connected to switches 1 to 4.

Above that field there is a picture showing the switch functionality as a schematic.

When the switch is unaffected by the LED-switch and CV, the in/out jack to the left is connected to the in/out jack below the G. Where G correspond to green on the channels LED-switch.

When the switch is affected by the LED-switch or CV, the in/out jack to the left is connected to the in/out jack below the R. Where R correspond to red on the channels LED-switch. Both the manual switch and the CV works as a gate signal.

If a channel is controlled via CV you can be temporarily override that by pressing the channels LED-switch and fix it to be connected to R as long as you hold the LED-switch. When released it will go back to CV control.

This way you can manually affect automated switching during a performance.

LED-switch 1 to 4 are momentarily switches when Latch is off.

When Latch is on the LED-switches will be toggling on/off when pressed.

Latch affects switches in pairs. 1 and 2 together and 3 and 4 together as shown on the front panel graphics.

CV control works just like the switches. When a CV signal is high the switch is on.

A high signal is about 0,7V and works with any logical or audio signal up to well above 100kHz. CV works like a gate signal. As long as CV is high the in/out jack will

be connected to R.

CV with Latch on. When Latch is on the switch will toggle on or off at every positive flank of the CV signal.

This can be used to flip the switch at a pulse from a sequencer.

It can also be used to add a subharmonic at audio rate switching as the switch toggles every second positive flank. But remember that CV is a a gate signal, not a trigger.

Device specs

Module size: 8 hp wide, 29 mm deep with power connector.

Input impedance: 100 kohm

Through impedance: 20 ohm

Max trough current: 30 mA

Power requirements: +12V. Max power consumption 30 mA

-12V. Max power consumption 5 mA

Connect the power cable with the red stripe (-12V) down.

The unit is protected for reverse power.

Note!

The max trough current of 30 mA will not be reached in normal use in a eurorack system as most modules can't supply more than 10 mA out. So shorting an output through the switch to ground is not a problem, plenty of margin there. But take care when connecting other equipment. You can for instance NOT connect a light bulb from plus through the Switch without limiting the current to below 30 mA at all times. If you don't the switching components will break.

Use case examples

A few examples, just to get your imagination going. Check the DPW Design YouTube for more examples.

Normal mute or bus switching

Use switch 1 and 2. Set the Latch to on.

Connect a stereo bus to 1G and 2G and another stereo bus to 1R and 2R.

You now have a selectable stereo bus out on 1 and 2.

By switching the Latch function on you can trigger the switching with a gate or trigger from a sequencer.

Gate switched sound source

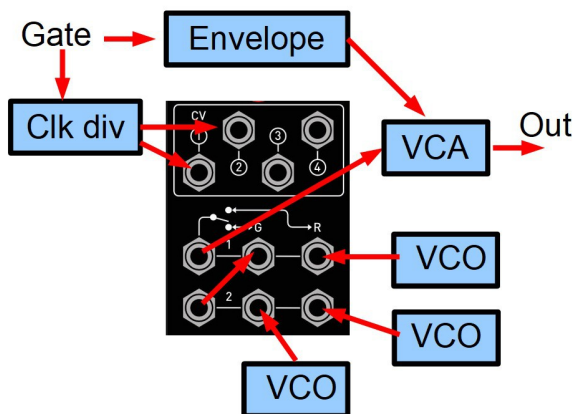

This is a patch making drum sounds with only one VCA, one envelope, a clock divider and 3 sound sources. Two channels of the switch will be used.

Connect the three VCOs or other sound sources as shown in the picture. The output from switch 1 will be the main out of the switch to the VCA.

The result will be a different sound at every gate pulse.

The patch can be expanded with the remaining two switch channels and more sound sources to make the sound less repetitive.

Audiorate Wave Splicing

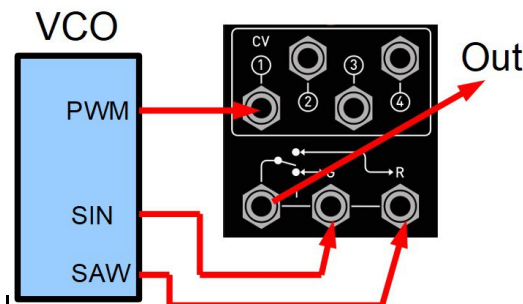

Replacing a part of a single cycle in an audio signal to get a new wave.

This is an example of using the PWM out of a VCO to control how large part of the wave that shall be sine or saw. By sweeping the PWM the sine/saw ratio can be modulated.

By switching the Latch function on the switching will occur every second cycle and in that way add a sub harmonic.

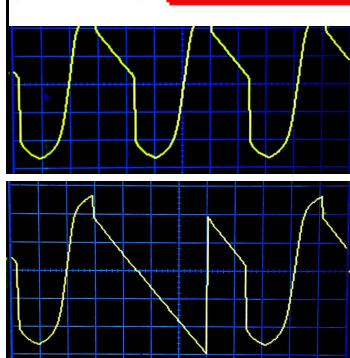

An example of where the PWM signal is switching from the sine to the saw and back. Replacing parts of the sine wave.

This can be animated from just sine over to just saw by controlling the PWM signal with an LFO.

The same as the picture above but with the Latch function on. It is switching every second time the PWM signal goes high. It adds a subharmonic and makes the wave a lot more interesting.

Note that this is the simplest possible wave shaping you can do with this technique. Adding more switches and control can be very interesting.

Please check www.dpw.se for updates of the manual and demo videos.